



# MODEL HV-100E Full-Size Electric Oven



HV-100E double shown

### OPTIONS AND ACCESSORIES

(AT ADDITIONAL CHARGE)

- **Legs/casters/stands:**
  - 6" (152mm) seismic legs
  - 6" (152mm) adjustable legs
  - 4-1/4" (108mm) low profile casters (double only)
  - 25" (635mm) stainless steel open stand with rack guides
- Extra stainless steel oven racks
- Additional core probe
- 480 VAC, 3 phase
- Chicken roasting rack
- French fry pan
- Water pressure regulator

Project \_\_\_\_\_

Item No. \_\_\_\_\_

Quantity \_\_\_\_\_

Standard depth baking compartment - accepts five 18" x 26" standard full-size baking pans in left-to-right positions.

All data is shown per oven section, unless otherwise indicated.

Refer to operator manual specification chart for listed model names.

### EXTERIOR CONSTRUCTION

- Fully welded angle-iron frame
- Stainless steel front, top, sides and back
- Simultaneous split door operation with catch-latch system
- Triple mounted door design with turnbuckle assembly
- Dual pane tempered viewing window with hinged inner glass for easy cleaning
- Modular slide out front control panel with major components for ease of service
- Retractable hand shower for ease of cleaning

### INTERIOR CONSTRUCTION

- 316 stainless steel coved corner liner for easy cleaning
- Five stainless steel racks and nine rack positions
- Two halogen interior lights for superior visibility
- Drain in oven cavity
- Hinged air pressure panel for easy cleaning
- Up to 2.5" of mineral board insulation for greater heat retention

### OPERATION

- Six tubular heater element design
- Core temperature probe
- MenuSelect control with 99 programs and 6 cooking stages
- Hydrovection cook mode with adjustable humidity control
- Hot air cook mode for baking and pastries
- One touch cooking
- Low temperature cooking and holding
- Four speed auto-reversing fan motor
- Cavity vent
- Thermostatically controled quench system, Eco-Friendly

### STANDARD FEATURES

- 25" (635mm) adjustable stainless steel legs (for single units)
- 6" (152mm) stainless steel casters (for double sections)
- 1 year parts and 1 year labor warranty



### BLODGETT OVEN COMPANY

www.blodgett.com

44 Lakeside Avenue, Burlington, VT 05401

Toll Free: (800) 331-5842 • Phone: (802) 860-3700 • Fax: (802) 864-0183

HV-100E



# MODEL HV-100E

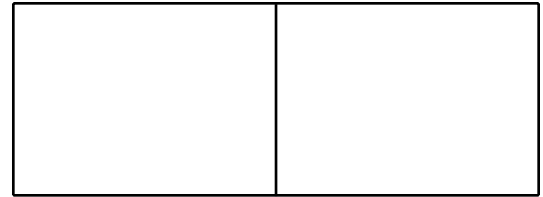

APPROVAL/STAMP

42.51 (1080)  
41.53 (1055)  
40.03 (1024)

DIMENSIONS ARE IN INCHES (MM)

TOP VIEW

3.20 (81)  
0 (0)  
3.65 (93)  
25.56 (649)

REAR VIEW

4.28 (109)  
2.97 (75)  
2.28 (58)  
0 (0)  
3.91 (99)  
2 places  
21.75 (553)  
32.75 (832)  
Cavity Vent  
38.07 (967)

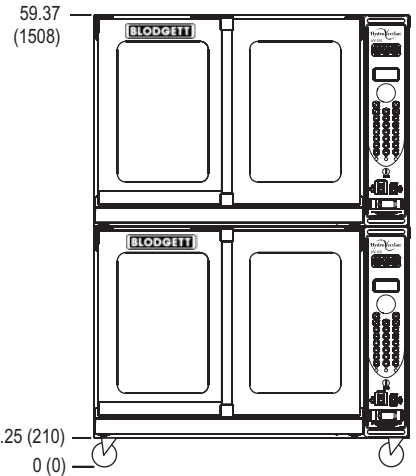
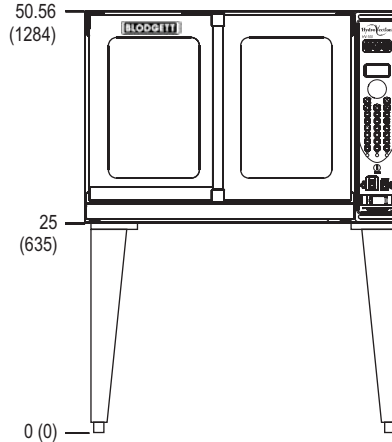

### SHORT FORM SPECIFICATIONS

Provide Blodgett full-size hydrovection oven model HV-100E. (single/double) compartment with fully welded angle iron frame. Each compartment shall have fully welded 316 stainless steel liner. Liner to be covered top and bottom. Unit shall accept five 18" x 26" standard full-size bake pans. Doors shall be triple mounted, stainless steel with dual pane thermal glass windows, single tubular handle and simultaneous operation. Unit shall be electrically heated by six tubular heaters. Air in baking chamber distributed by single inlet blower wheel powered by a four speed, auto-reversing, 1/2 HP motor with thermal overload protection. Each chamber shall be fitted with bright halogen lamps, and five standard stainless steel removable racks. Retractable hose reel mounted just below the control for easy cleanup. Control panel shall be programmable MenuSelect with moisture control, low temperature Cook and Hold and the ability to program up to 99 six stage recipes. Breaker shut off switch on front panel for easy service. 1 year parts and 1 year labor warranty Provide options and accessories as indicated.

### DIMENSIONS:

**Floor space** 38.07" (967mm) W x 40.03" (1024mm) D  
**Interior** 29" (737mm) W x 20" (508mm) H x 23.43" (595mm) D  
**Single oven on casters** Add 4-1/2" (114mm) to height  
**Product clearance from combustible and non-combustible construction.**  
**Oven sides** 0" (0mm) Blodgett recommends 4" clearance from any heat source on the control panel side of the oven, an optional heat shield should be considered  
**Oven back** 6" (152mm)

### WATER & DRAIN CONNECTION (per section):

1" NPT drain connection  
 3/4" NPT garden hose - cold water only

### WATER SUPPLY (per section):

Good quality water feed is the responsibility of the owner. The use of water that is not within the following guidelines will void the warranty.

TDS: < 100 ppm Hardness: 80-120 ppm pH: 7.0 - 8.0  
 Chlorides: < 30 ppm 30(min)-50(max) PSI 140°F (60°C) avg. drain temp.

The best defense against poor water quality is a water filter system designed to meet your water quality conditions. **Filtered water is highly advised.**

**Water Consumption** 2.5 - 3.0 GPH

**NOTE:** The company reserves the right to make substitutions of components without prior notice

### MAXIMUM INPUT:

Single 13kW  
 Double 26kW (13kW each section)

### POWER SUPPLY:

V.A.C.	Hz	Phase	kW	Amperes (L1-L2-L3)
208	60	3	13	38/38/34
240	60	3	13	30/30/28
440	60	3	11	16/16/14
480	60	3	13	17/17/15

1/2 H.P., 3 phase motor

### MINIMUM ENTRY CLEARANCE:

Uncrated 25.56" (649mm)  
 Crated 37-1/2" (953mm)

### SHIPPING INFORMATION:

**Approx. Weight**  
 Per section 450 lbs. (204 kg)  
**Crate sizes**  
 37-1/2" (952mm) x 43-1/2" (1105mm) x 51-3/4" (1315mm)  
 (2 crates required for double)

### BLODGETT OVEN COMPANY

www.blodgett.com

44 Lakeside Avenue, Burlington, VT 05401 Toll Free: (800) 331-5842 • Phone: (802) 860-3700 • Fax: (802) 864-0183