



PRODUCT: _____

SKU NUMBER: _____

QUANTITY: _____



300-5356: 2.2gpm/8.3lpm @ 1000psi/76bars, 115V
300-5357: 2.2gpm/8.3lpm @ 1000psi/69bars, 208V
300-5358: 2.9gpm/11lpm @ 850psi/59bars, 115V
300-5359: 2.9gpm/11lpm @ 800psi/55bars, 208V

The SMT 600W is our most popular High Pressure Wash Down System. Why? Because its core features make it the most durable, reliable and affordable cleaning & sanitizing system on the market.

The industrial pumping unit of SMT 600W is complimented with heavy duty accessories and safety features that insure compliance and ease of use. And, with a 5000 hour rating, the SMT 600W will be your primary cleaning & sanitizing solution for years to come.

FEATURES

- 2hp Motor TEFC, 1725rpm, 1 phase Draws 15A
- 3 cylinder CAT® super flow plunger pump
- SMT-200-RW manual rewind hose reel
- Quick coupler set (connects hose to unit)
- Quick coupler set (connects gun to hose)
- 50ft/15.3m high pressure hose (steel braided)
- Anti-backflow protection/float tank
- Water Level Float Switch Assembly
- Adjustable chemical injector
- Sanitizer chemical selector with flush feature
- 2 1gal/3.8L chemical baskets
- Pressure gauge, 2000psi/138bars, liquid filled
- Stainless steel cover and frame
- Stainless steel wall mount brackets with gun hanger
- 16ft/2m- water inlet supply hose
- 4ft/1.3m Cord with GFC
- Maintenance Kit: Water filter, replacement filter and two hydraulic oils
- ETL-CSA listed to UL 1776
- Shipping Weight: 239lb/104.3kg

600WDF Wall Mount System

INCLUDED PRODUCTS



Spray Master Technologies®

TOLL FREE: 800.548.3373

115 E. LINDEN, ROGERS, ARKANSAS 72756 USA

PHONE: +1 479.636.5776

FAX: +1 479.636.3245

WWW.SPRAYMASTERTECH.COM

600WDF Wall Mount System

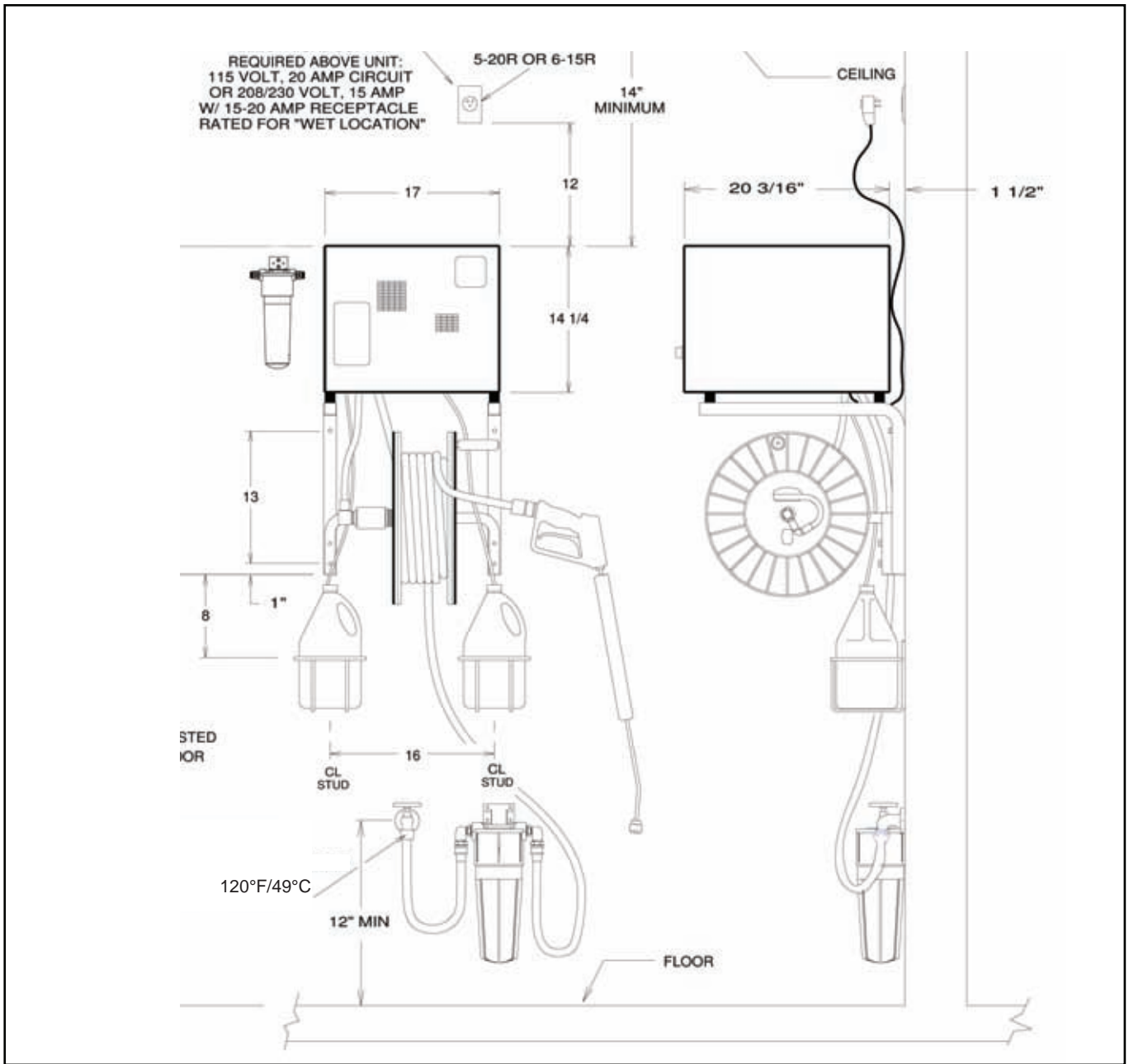

Equipment Specifications

Clearances

Left side	12"/30cm
Right side	12"/30cm
Overhead	14"/35cm
Floor	36"/91cm
Front	36"/91cm

Plumbing

3/4"/2cm Hose Bib with 5gpm/.14Lpm @
30psi/20.6bars. 120°F/49°C Max

Electrical

115V, 20A dedicated circuit or
208-230V, 9A GFCI.

Installation Specifications

Electrical:

One (1) 115V, 60hz, single phase, 20A, 'Dedicated Circuit' with standard receptacle. NOTE: For 208V or 230V units a 15A wall receptacle is required.

Water:

One (1) warm water outlet 120°F/49°C MAX with standard 3/4"/1.9cm hose bib with shut-off valve. A pressure gauge in the water line can be helpful although it is not mandatory. A minimum of 5 gal. / 19L per minute and a line pressure not less than 30psi/20.6bars, is required.

Location:

Heated utility room or closet with ventilation. Minimum 14in/.35m clearance above unit required to remove cover. The cover must be removed for servicing the unit. The unit can be serviced without removing it from the wall.

General Recommendations:

Floor drains are essential in new facilities to receive the greatest utilization and maximum efficiency of your SPRAY MASTER Pressure Washer. Floor materials and wall coverings which can be cleaned with pressurized water are desirable. Locate electrical outlets above washing areas.